

Quick Connect

For Detachable Rigid Riser Tubes



Pressure Management, Simplified: Clear, easy-to-clean detachable tube offers a game-changing solution for poultry growers.

Advantages

- **Maintenance:** Effortless detachment simplifies cleaning.
- **Operational:** Ability to remove tubes prior to bird processing without disrupting water supply.
- **Performance:** Transparent tube provides a clear view of the float ball for accurate water supply monitoring.
- **Longevity:** Durable design prevents damage and extends product lifespan, reducing maintenance costs.
- **Compatibility:** Adapts to all flex tube nipple systems on the market for seamless integration and flexibility.



Technical Specifications

- Available in 16" and 24" clear rigid tube lengths
- Adapts to barbed, slick or 1/4" male threads
- Pressure tested up to 80 PSI during flush mode



Gray Quick Connect
Part #7TEF026



White Quick Connect
Part #7TEF027



Threaded Quick Connect
Part #7TEF024

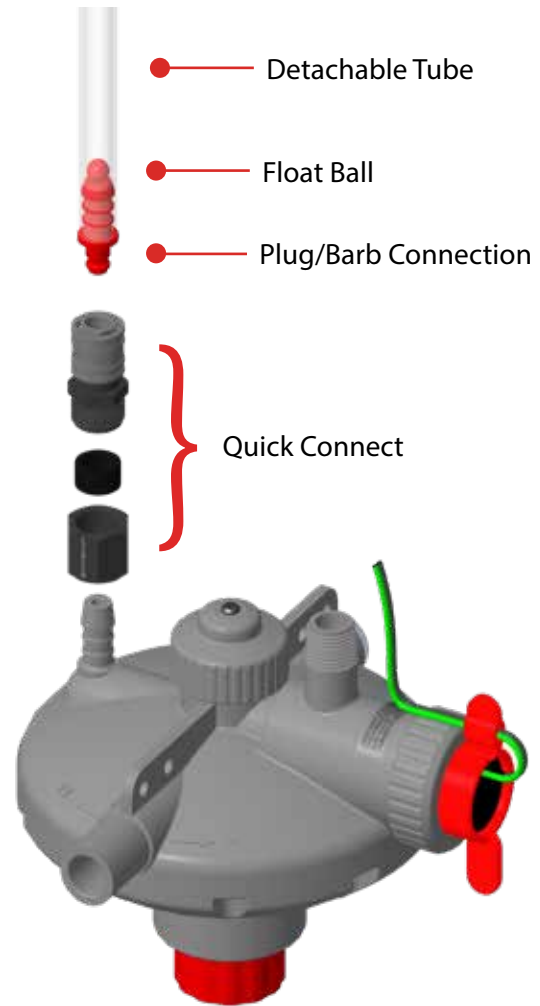

Quick Connect Models

Nipple Compatibility in 24" Length 16" Length	Gray #2205439G24 #2205439G16	White #2205439W24 #2205439W16	Threaded #2205439 #2205439R16
Plasson	X		
Lubing	X		
Ziggity		X	
Chore-Time		X	
Val		X	
Cumberland	X		
Plasson Threaded			X
Hog Slat Regulator			X
Impex	X		



556 Industrial Way W, Eatontown, NJ 07753 • 1-800-348-6663 • info@DiversifiedAg.com

DiversifiedAg.com