

Green
Climate

Installation Manual



Green Climate

Climate Controller

Ag/MIS/UmEN-2731-05/19 Rev 1.2

P/N: 116781

 **Munters**

Green Climate

Installation Manual

Revision: N1.2 of 11/19
Product Software: 8.2

This manual for use and maintenance is an integral part of the apparatus together with the attached technical documentation.

This document is destined for the user of the apparatus: it may not be reproduced in whole or in part, committed to computer memory as a file or delivered to third parties without the prior authorization of the assembler of the system.

Munters reserves the right to effect modifications to the apparatus in accordance with technical and legal developments.

Index

<i>chapter</i>		<i>page</i>
1	INTRODUCTION	5
1.1	Disclaimer	5
1.2	Introduction	5
1.3	Notes	5
2	INTRODUCTION	6
2.1	Getting Started	6
2.2	Main Menu Screen	6
2.3	User Level Access	7
2.4	Quick Access	8
3	HARDWARE INSTALLATION	9
3.1	Basic Requirements for On-Site Preparation	9
3.2	Frequency Inverters	9
3.3	General Dimensions	10
3.4	Power Supply Wiring	11
3.4.1	Main Power Wiring	11
3.4.2	Electric Test	12
3.5	Hardware Layout	13
3.6	Wiring	14
3.6.1	Digital Output	14
3.6.1.1	24 VAC	14
3.6.1.2	Dry Contact	15
3.6.2	Digital Inputs	16
3.6.3	Analog Inputs	17
3.6.3.1	Measuring Box, Water Temperature, and CO ₂ Sensors and Wiring (Analog Input)	18
3.6.3.2	Weather Station Devices and Wiring (Analog/Digital Inputs)	20
3.7	Network Communication Wiring	21
3.7.1	Expansion Unit Connections	22
3.7.1.1	Option A: RS-485 Wiring	23
3.7.2	Expansion Unit Settings	24
3.7.3	Comm-Box Wiring	26

4	SYSTEM INSTALLATION AND CONFIGURATION	27
4.1	Firmware Upgrade	27
4.1.1	Accessing the Application	27
4.1.2	Running the Application	28
4.2	Cold Start	29
4.3	System Installation (Menu 8.1)	30
4.3.1	Digital Outputs (Menu 8.1.1)	30
4.3.1.1	Test Relay - Digital Outputs (Menu 6.1)	31
4.3.2	Digital Inputs (Menu 8.1.2)	31
4.3.2.1	Test Digital Inputs (Menu 6.3)	32
4.3.3	Analog Inputs (Menu 8.1.3)	32
4.3.3.1	Test Analog Inputs (Menu 6.2)	33
4.3.4	View Hardware Checklist (Menus 8.1.4 & 7.10.7)	33
4.4	Climate Zone Configuration	34
4.4.1	Zone Configuration (Menu 8.2.11)	34
4.4.2	Measuring Box Allocation (Menu 8.2.10)	35
4.4.3	Vent (Menu 8.2.1)	36
4.4.4	Screen (Menu 8.2.2)	37
4.4.5	Heating (Menu 8.2.3)	38
4.4.5.1	Heating Network – P & I Tuning Process	39
4.4.6	Misting (Menu 8.2.4)	40
4.4.7	Fan & Pad (Menu 8.2.5)	42
4.4.8	Air Circulation (Menu 8.2.6)	43
4.4.9	CO2 (Menu 8.2.7)	44
4.4.10	Crop Protection (Menu 8.2.8)	44
4.4.11	Light (Menu 8.2.9)	45
4.5	Boiler Configuration	45
5	TECHNICAL SPECIFICATIONS	47
6	POWER SUPPLY SPECIFICATIONS	48
7	WARRANTY	49

1 Introduction

1.1 Disclaimer

Munters reserves the right to make alterations to specifications, quantities, dimensions etc. for production or other reasons, subsequent to publication. The information contained herein has been prepared by qualified experts within Munters. While we believe the information is accurate and complete, we make no warranty or representation for any particular purposes. The information is offered in good faith and with the understanding that any use of the units or accessories in breach of the directions and warnings in this document is at the sole discretion and risk of the user.

1.2 Introduction

Congratulations on your excellent choice of purchasing a Green Climate!

In order to realize the full benefit from this product it is important that it is installed, commissioned and operated correctly. Before installation or using the fan, this manual should be studied carefully. It is also recommended that it is kept safely for future reference. The manual is intended as a reference for installation, commissioning and day-to-day operation of the Munters Controllers.

1.3 Notes

Date of release: July 2019

Munters cannot guarantee to inform users about the changes or to distribute new manuals to them.

All rights reserved. No part of this manual may be reproduced in any manner whatsoever without the expressed written permission of Munters. The contents of this manual are subject to change without notice.

2 Introduction

Munters Green Climate is a climate controller that brings to the user the tool to control the climate condition to the optimum desired level inside the climate zone. Munters Green Climate is designed to control up to four climate zones in a single controller.

- Getting Started
- Main Menu Screen
- User Level Access
- Quick Access

2.1 Getting Started

- Installation should be performed by authorized technicians only.
- Verify that all components are working properly.
- All safety regulations are to be applied.
- Do not apply force or pressure on components during the installation procedure.
- Refer to your supervisor if problems occur during installation procedure.

CAUTION This unit must be installed inside, in a location protected from solar radiation and direct rain.

2.2 Main Menu Screen

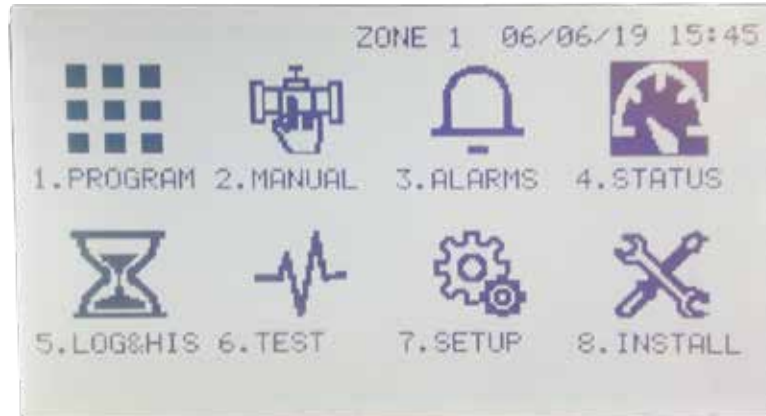

2.3 User Level Access

There are three access levels:

- **Read Only (restricted):** All the parameters and menus are visible, but cannot be modified
- **User (limited restriction):** Menus 1-7 are fully accessible and can be modified. Menu 8 can be viewed but not edited
- **Technician (unrestricted):** All menus are fully accessible and available for modifications

To change the operation mode:

1. On the main menu press .

2. Use arrow keys to select **YES**.

3. Press .

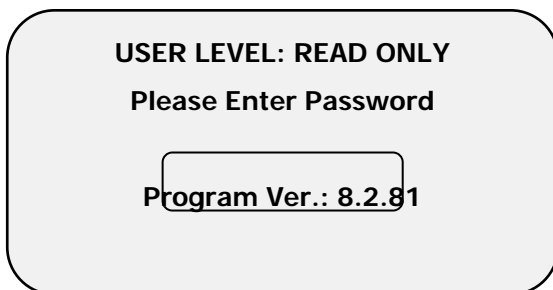
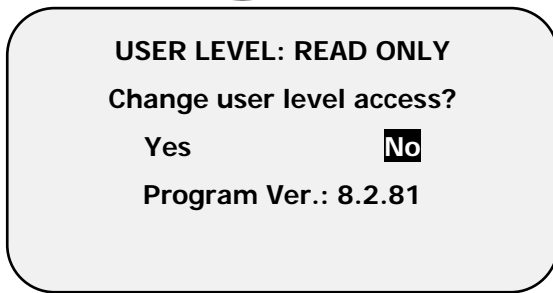

The controller recognizes the operation mode according to the password that is entered:

USER LEVEL	PASSWORD
Read Only	0000
User	9999
Technician	1948

Technician level access enables modifying all menus. User level access enables modifying all menus except the installation menu.

2.4 Quick Access

Use the Quick Access feature in order to navigate into any screen by entering in the corresponding numeric keys of the menu (top left of screen) from the Main Menu screen. There is a permanent order in

the layout of the screens. For double digit numbers, use the  key for the ten's place and then the corresponding one's place number

- Vent
- Screen
- Heating
- Misting
- Fan & Pad
- Air Circulation
- CO2
- Crop Protection
- Light

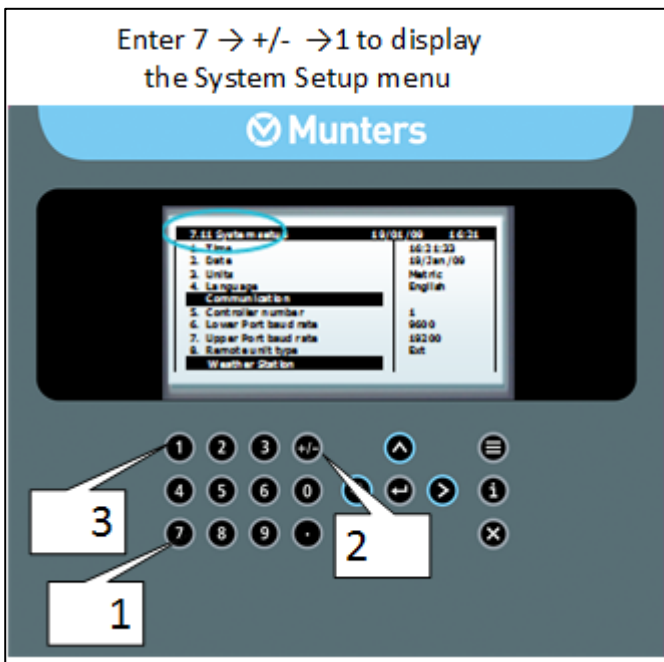

3 Hardware Installation



CAUTION! SHOCK HAZARD! Only a qualified electrician may perform the electrical

- Basic Requirements for On-Site Preparation
- Frequency Inverters
- General Dimensions
- Power Supply Wiring
- Hardware Layout
- Wiring
- Network Communication Wiring

3.1 Basic Requirements for On-Site Preparation

- Verify power source between 115 VAC or 220 VAC or 12VDC. (Australia & New Zealand 240 VAC \pm 5%).
- On the unit is a silver label stating the unit's voltage (110 or 230 VAC). **Verify that your unit supports the voltage supplied in your country.**
- Verify grounding connection $<10\Omega$.
- Environment temperature between (-10°C/14°F)-(+60°C/140°F).
- Verify protection from damaging climate conditions.

3.2 Frequency Inverters

- Frequency inverters can cause severe electrical and electromagnetic interference. Therefore, when employing a frequency inverter, it is critical that you carefully follow the manufacturer's installation instructions .
- In particular verify:
 - that the cable shielding between the inverter and any motor meets industry standards
 - proper grounding of the inverter's chassis and motor power cable
 - proper grounding of low voltage cable shield wire
 - that the controller and inverter cables are kept in separate conduits or wire bundles

3.3 General Dimensions

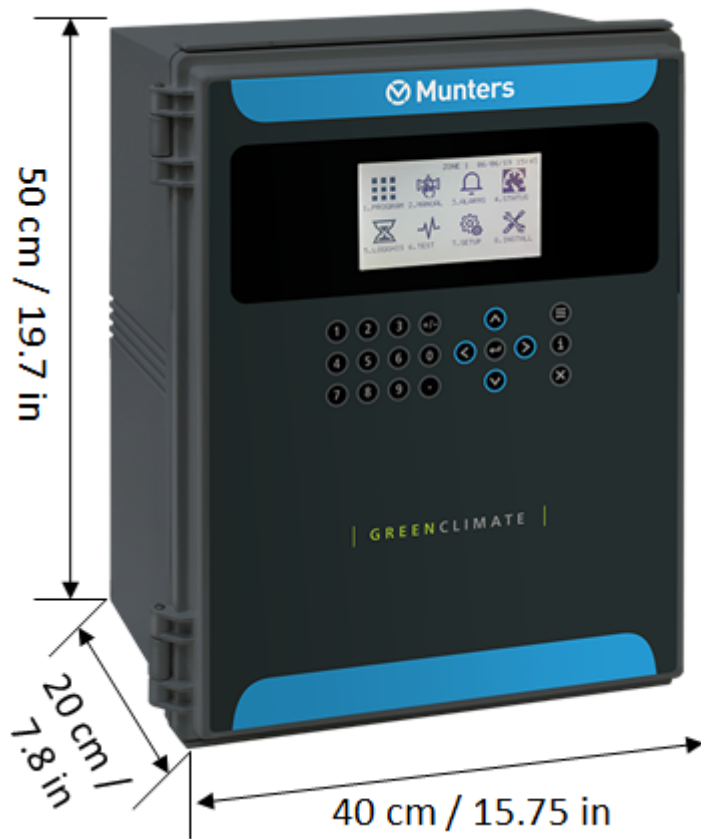

3.4 Power Supply Wiring

- Main Power Wiring
- Electric Test

3.4.1 MAIN POWER WIRING

Feed 3-wire cable through controller's gland and route into the controller (cable: 3 x 1.5 mm² or 3 x 16 AWG)

1. Grounding wire to Grounding terminal
2. Neutral wire (blue) to **Neutral (N)** in connector terminal
3. Phase wire (brown) to **Line (L)** in connector terminal

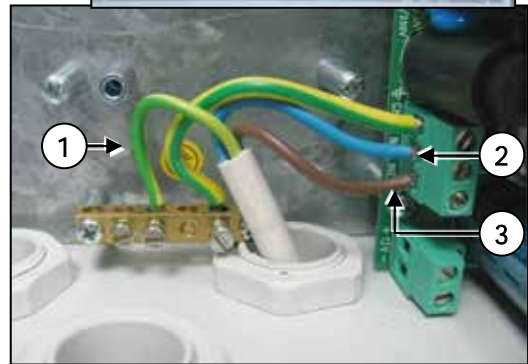
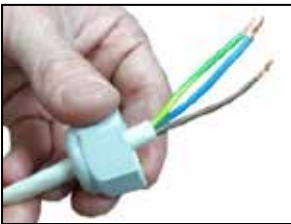

3.4.2 ELECTRIC TEST



CAUTION! SHOCK HAZARD! Only a qualified electrician may perform the electrical

Perform an electrical test using a multimeter:

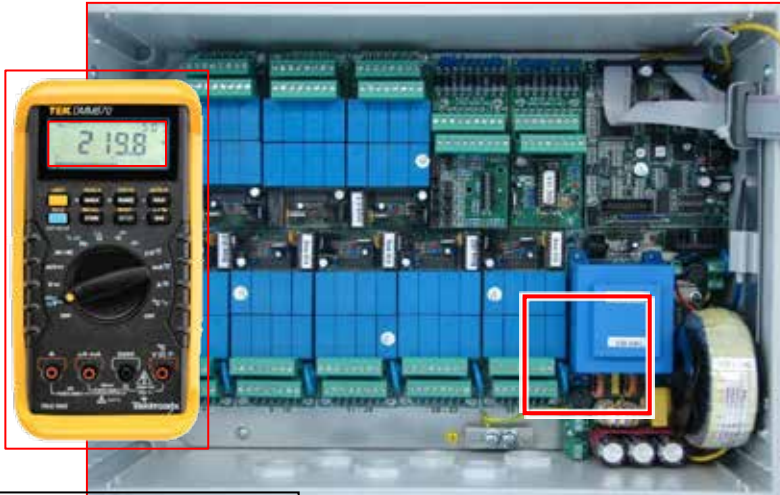

(2) **RED** probe to **LINE**
BLACK probe to
NEUTRAL

(1) **RED** probe to **LINE**
BLACK probe to **GND**

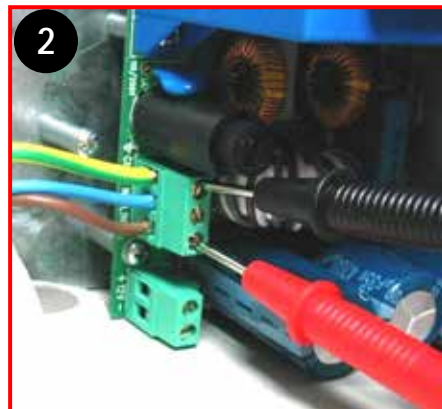
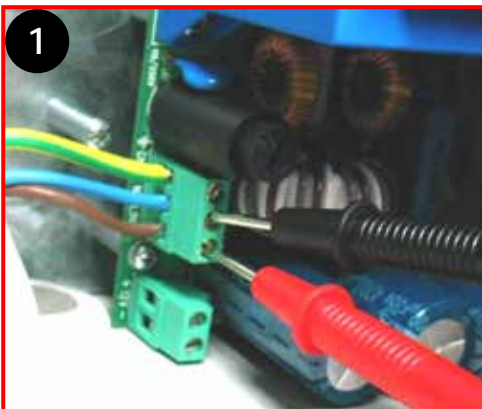

Multimeter results should read:

- EUR, AFR: 220 VAC \pm 10 %
- USA, MEX: 115 VAC \pm 10%
- AUS, NZ: 240 VAC \pm 5%

3.5 Hardware Layout

The following is a sample card layout for the Green Climate Controller.

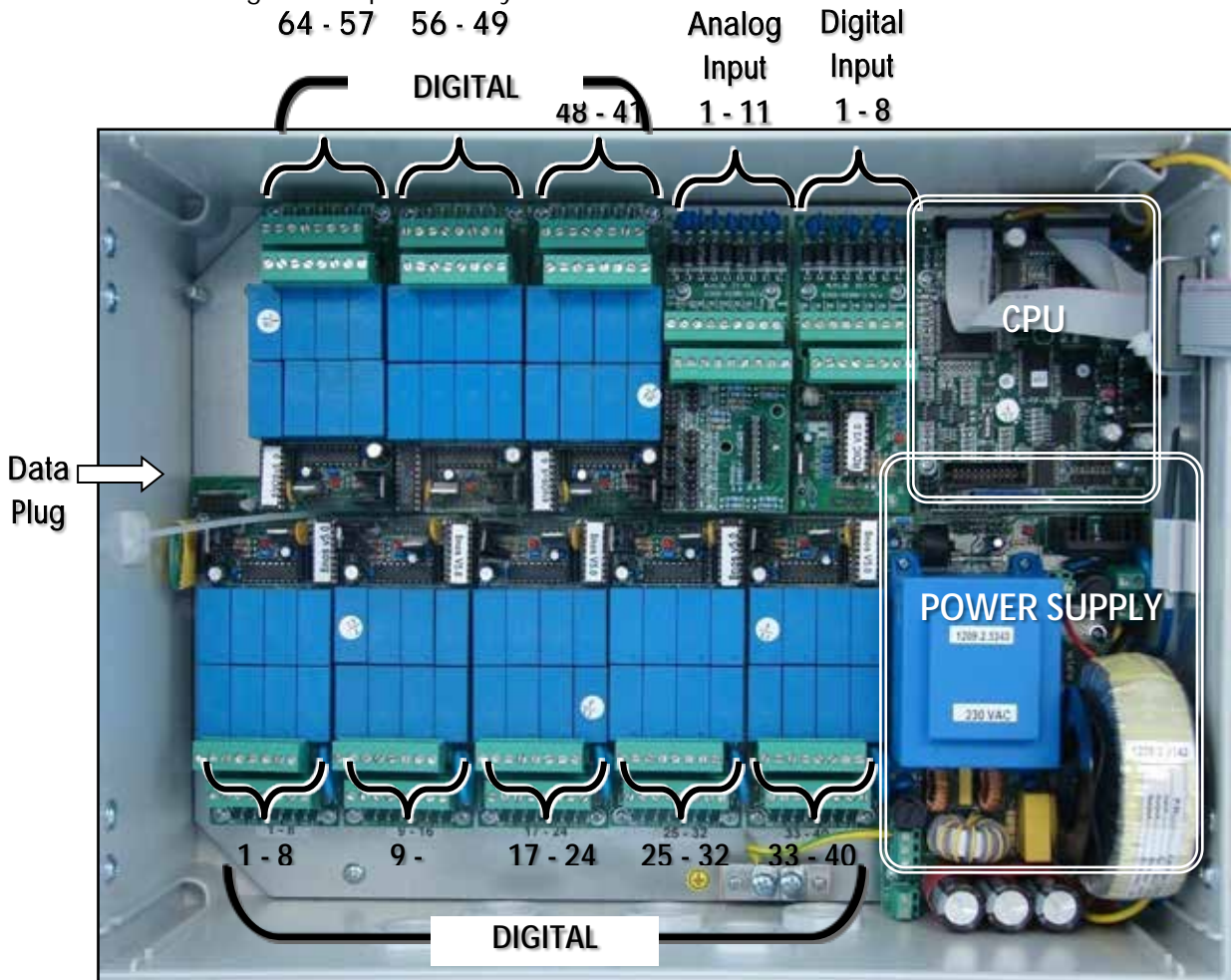

3.6 Wiring

- Digital Output
- Digital Inputs
- Analog Inputs

3.6.1 DIGITAL OUTPUT

- 24 VAC
- Dry Contact

3.6.1.1 24 VAC

- The Green Climate can consists of a maximum of 8 output cards, 5 of which can be 24VAC output cards; each card consists of 8 outputs, in total maximum 40 outputs 24VAC.
- The 24VAC output card is used to drive devices that require a 24VAC power supply. The upper row consists of the common connections and the bottom row of the outputs.
- It is possible to connect the common of several devices to the same connector nevertheless it is recommended to try and spread the commons in an even manner.
- The 24VAC output card consists of surge and lightening protection circuits and does not need the addition of external protections under normal conditions.

Specifications

8-40 N.O. low power relay 24VAC Output:	5 Amps
Maximum Output Changing Rate:	0.4 Sec

Optional Digital Output Devices:

- Vent Open
- Vent Close
- Screen Spread
- Screen Collect
- Air Circulation
- Mix Vent Open
- Mix Vent Close
- Circulation Pump Low Spray
- Circulation Pump High Spray
- Manifold Supply
- Manifold Return
- Heating On/Off
- Flow Mix Valve Open
- Flow Mix Valve Close
- Flow Circulation Pump Low Speed
- Flow Circulation Pump High Speed
- Misting Pump
- Misting Valve
- Crop Protection Prepare
- Crop Protection Spray
- Crop Protection Process
- Crop Protection Purge
- Light String
- Co2 Transport
- Co2 Valve
- F&P Fan Stage
- F&P Pad Pump
- F&P Inlet Open
- F&P Inlet Close
- General Alarm
- Boiler On

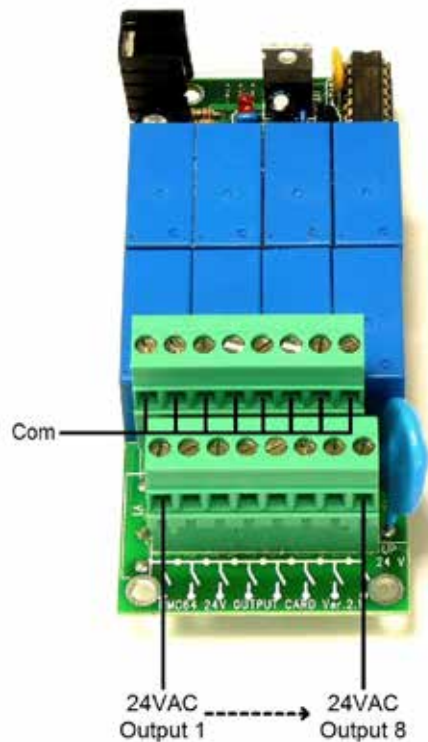

3.6.1.2 Dry Contact

The Green Climate consists of a maximum of eight output cards, all of which (or some) can be dry contact output cards; each card consists of eight outputs, in total maximum 64 dry contact outputs.

The dry contact output card can be used to drive devices of various voltages depending on what is connected to it. When more than 40 outputs of type 24VAC are required the dry contact output card can be configured as seen in drawing below.

The dry contact output card consists of surge and lightning protection circuits and doesn't need the addition of external protections under normal conditions.

Specifications

8-64 N.O. low power relay Dry Contact Output	5 Amps
Maximum Output Changing Rate	0.4 Sec
Optional Digital Output Devices: Same devices as at the table above	

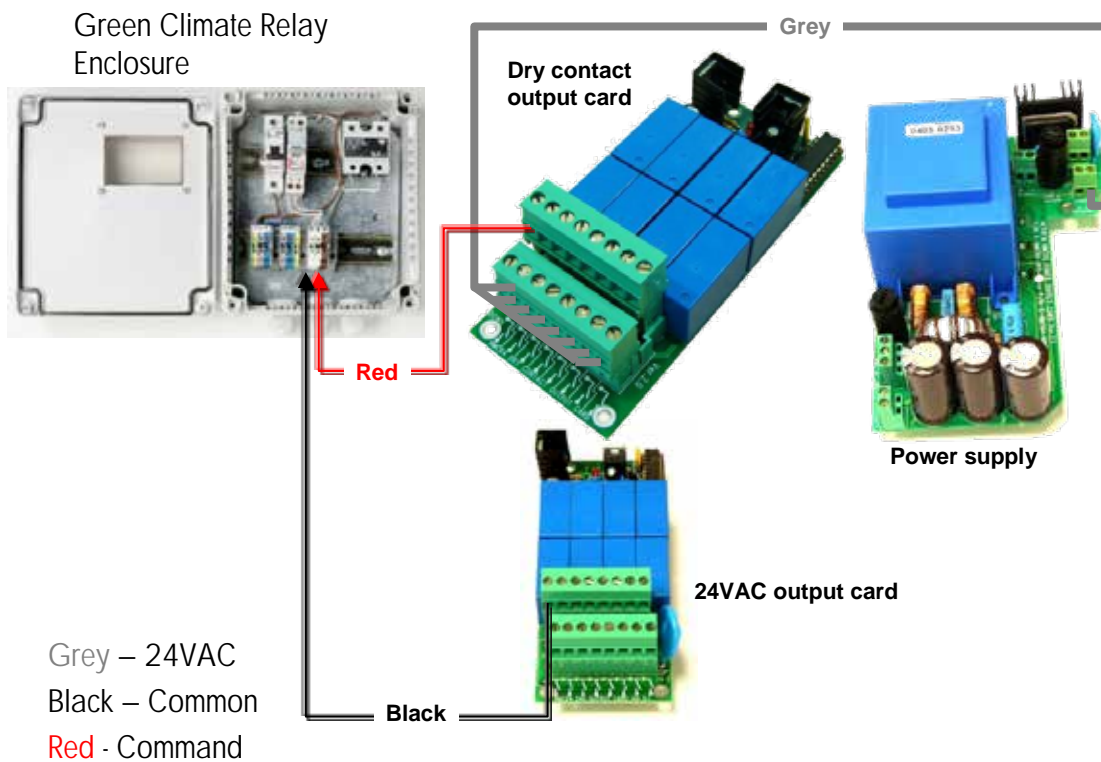

3.6.2 DIGITAL INPUTS

The Green Climate consists of a maximum of 3 digital input cards; each card consists of 8 inputs, in total maximum 24 digital inputs.

The digital input cards are used to measure discrete sensors. The bottom row consists of the common connections and the upper row of the inputs.

It is possible to connect the common of several sensors to the same connector nevertheless it is recommended to try and spread the commons in an even manner.

The digital inputs card consists of surge and lightening protection circuits and does not need the addition of external protections.

Specifications

8-16 digital inputs dry contact	5V/2mAmp
Maximum Pulse Input Rate	100 Pulse/Sec

3.6.3 ANALOG INPUTS

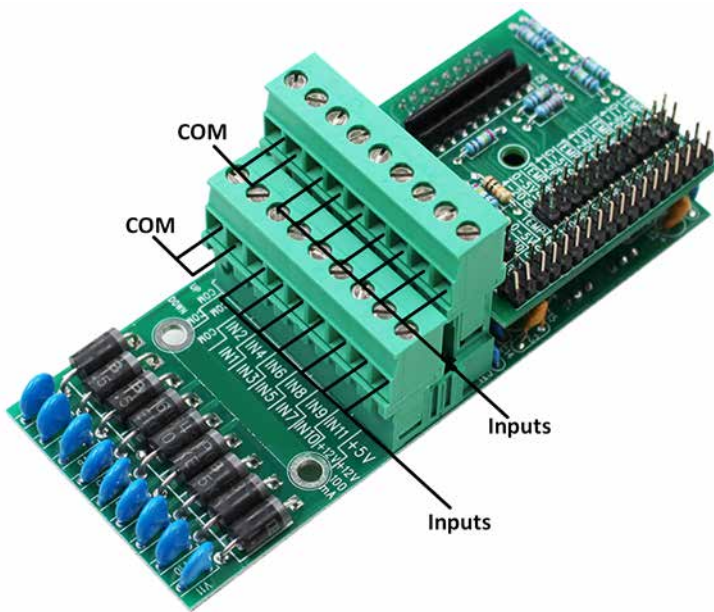

The Green Climate can contain a maximum of four analog input cards. Each card consists of 11 inputs; in total 44 analog inputs are available per local controller. Expansion boxes can contain a maximum of three analog input cards (Maximum amount of analog inputs in a single network is 256). The Analog input card enables defining each input's function using jumpers.

The card supports the following options:

- Inputs 1 – 10 can be connected to temperature sensor, 0 – 5VDC sensors (for example humidity sensors) or 4-20 mA sensors (for example CO₂ sensor).
- Input 11 can be connected to all three options mentioned above, and in addition to the wind direction sensor.

Optional Digital Input Devices:

- External Contact
- Rain Detector
- Snow Detector
- Vent Opened/Closed
- Screen Spread/Collected

The analog input consists of 12VDC, the 12VDC can be used to drive sensors (for example: humidity sensors) with a maximum current of 100mA.

NOTE Make sure not to overload the 12VDC supply as this might damage the analog input card.

The Analog inputs card consists of surge and lightning protection circuits and does not require additional external protections.

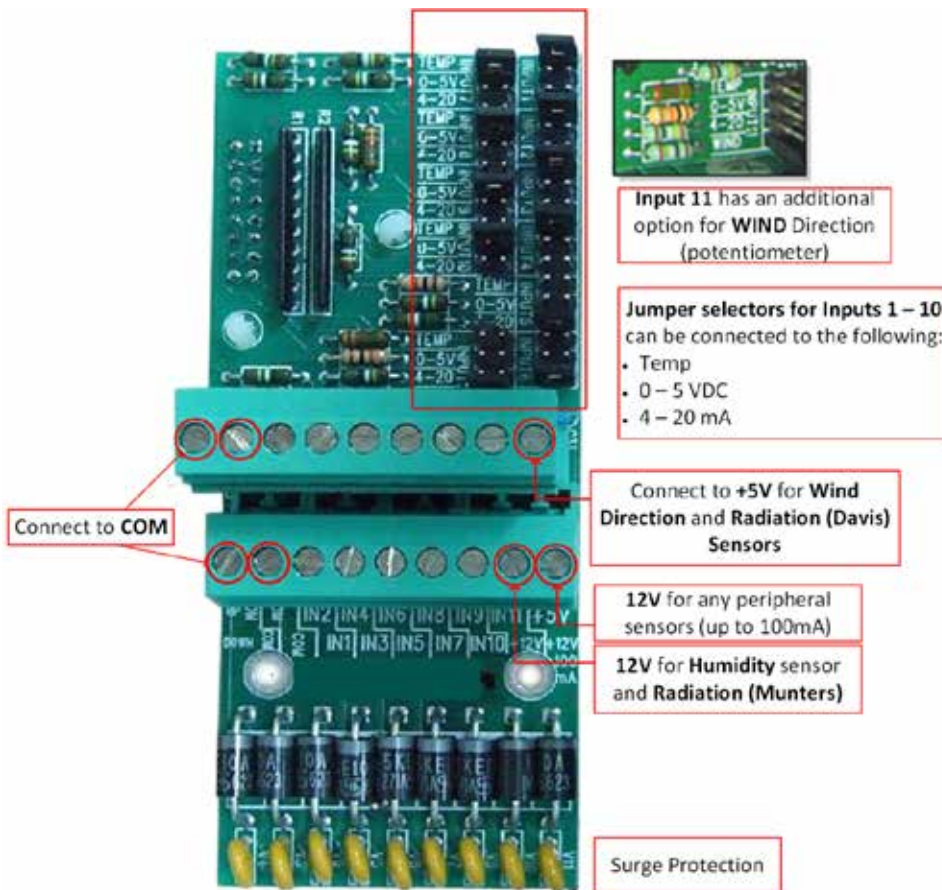

- Measuring Box, Water Temperature, and CO₂ Sensors and Wiring (Analog Input)
- Weather Station Devices and Wiring (Analog/Digital Inputs)

3.6.3.1 Measuring Box, Water Temperature, and CO₂ Sensors and Wiring (Analog Input)

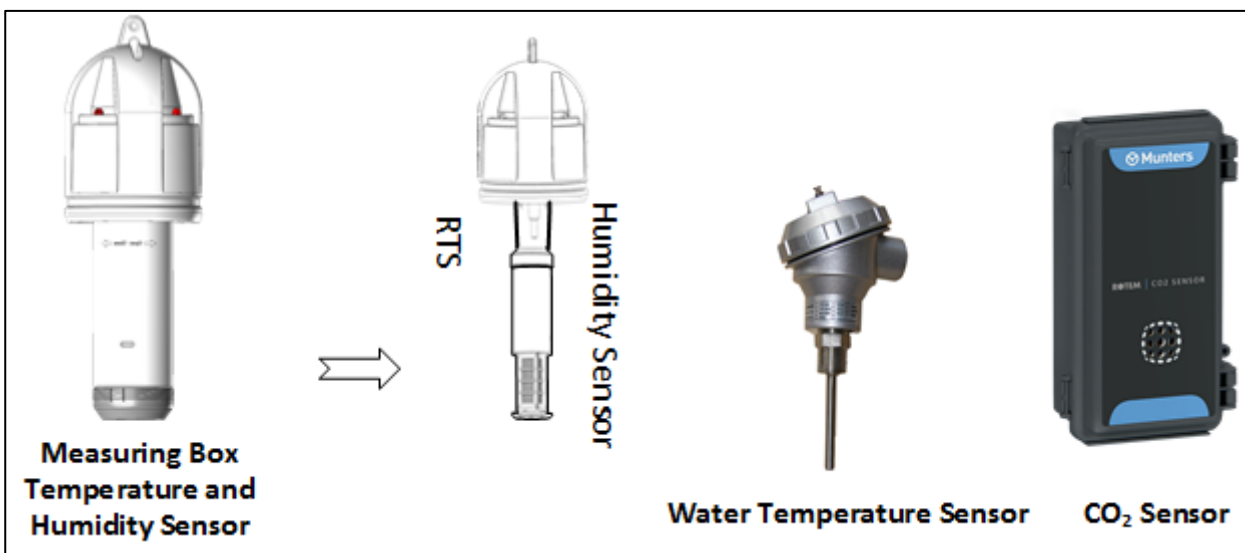



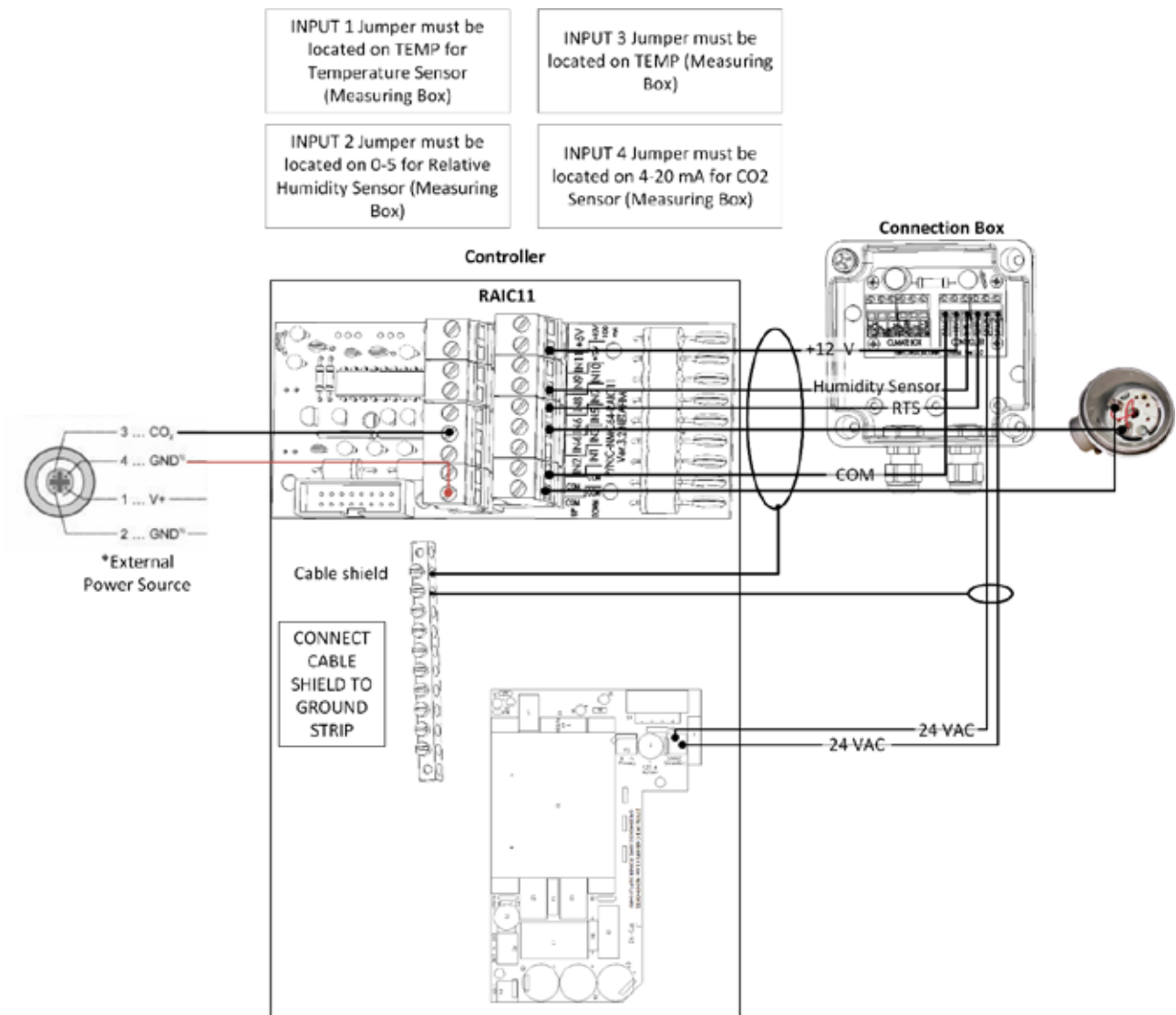

Analog Sensors		Measured Values	Input Range	Sensor Power Supply
Measuring Box	Air Temperature	-20° to +50°C/ -4° to +122° F	30 kOhm	Not applicable
	Relative Humidity	0 – 100%	0 – 3 VDC	12 VDC
Water Temperature		0° to +150°C/ 0° to +302° F	30 kOhm	Not applicable
CO ₂ Sensor – EE82 <i>*NOTE: Each sensor must have an external power supply.</i>		0 – 5000 ppm	4 – 20 mA	15-30 VDC



3.6.3.2 Weather Station Devices and Wiring (Analog/Digital Inputs)



	Wind Speed and Wind Direction
	Temperature and Humidity Sensor
	Radiation
	Rain Detector
	Rain Collector

Analog Sensors	Measured Values	Input Range
Temperature – RTS-s (outside temp)	-20° C to 50° C/ -4° F to 122° F	30kOhm
Relative Humidity – RHS-10	0 – 100%	0 – 3 VDC
Wind Direction - Davis	0 - 360°	0 – 20kOhm
Solar Radiation	0 – 1800 w/m ²	0 – 5 VDC
Digital Sensors	Measured Values	Input Range
Wind Speed	4-280 km/hr (2-175 mph)	Pulse output (Wind Cups & Magnetic Switch)

Rain Collector	Rain amount (mm or inch) Collection area: 200 cm ² (31 in ²) Resolution: 0.254mm (0.01")	Dry contact (tipping bucket)
Rain Detector	Rain, No Rain	Dry contact / 0-5VDC

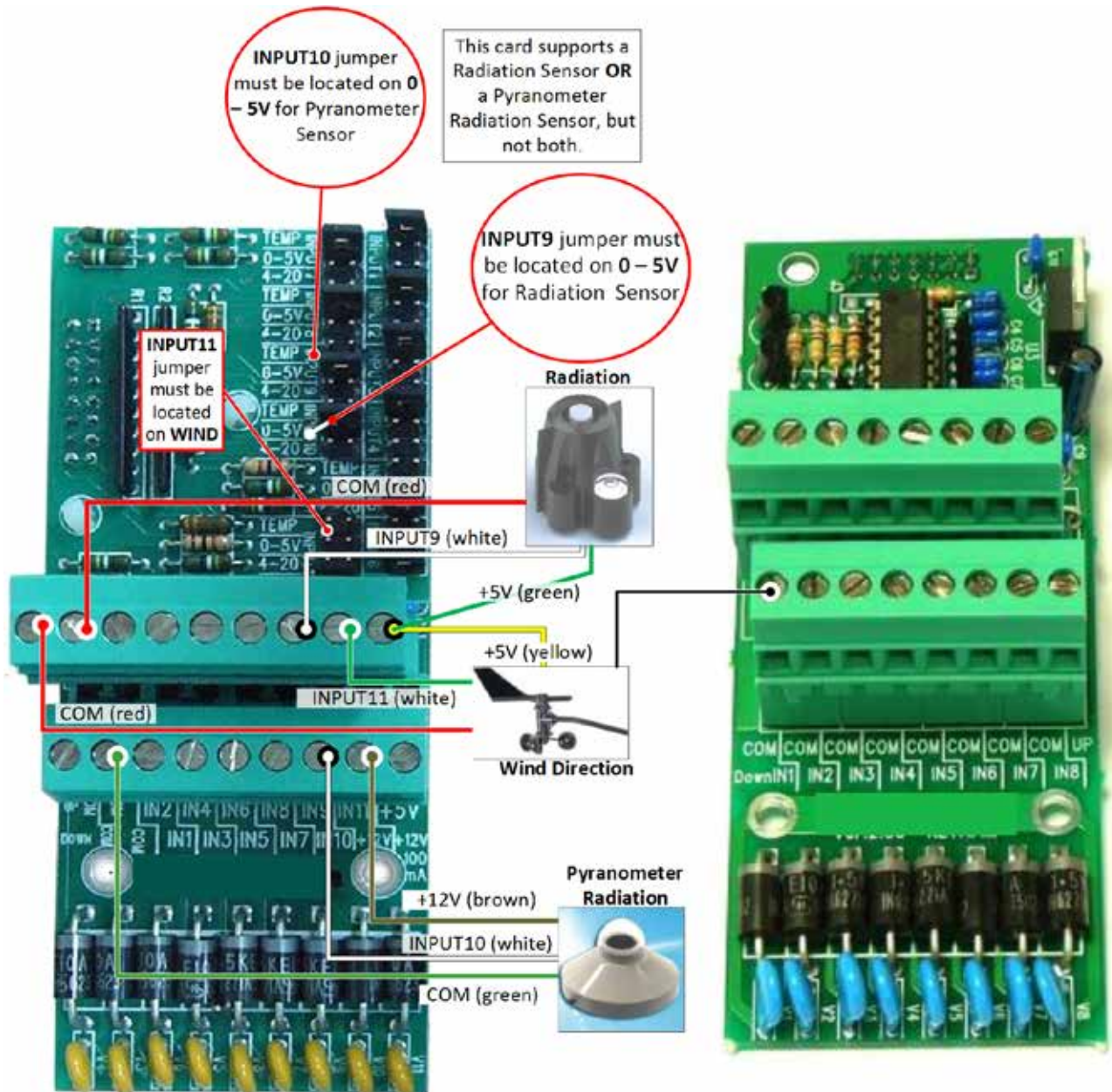

3.7 Network Communication Wiring

NOTE You can install up to 10 Green Climate Controllers in a single network, with each controller having up to four zones.

- Expansion Unit Connections
- Expansion Unit Settings

- PC and Inter-Controller Connections

3.7.1 EXPANSION UNIT CONNECTIONS

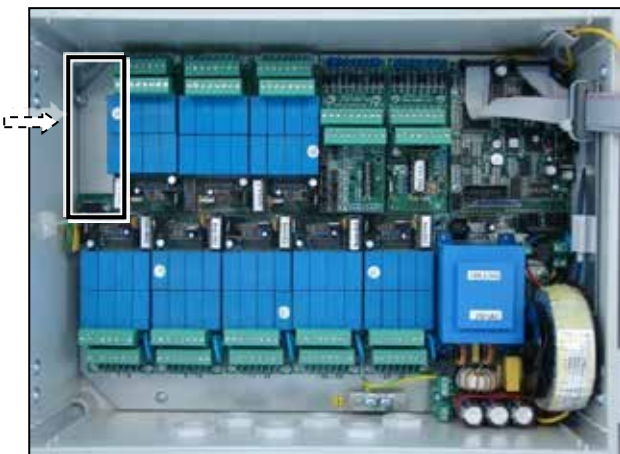

3.7.1.1 Option A: RS-485 Wiring

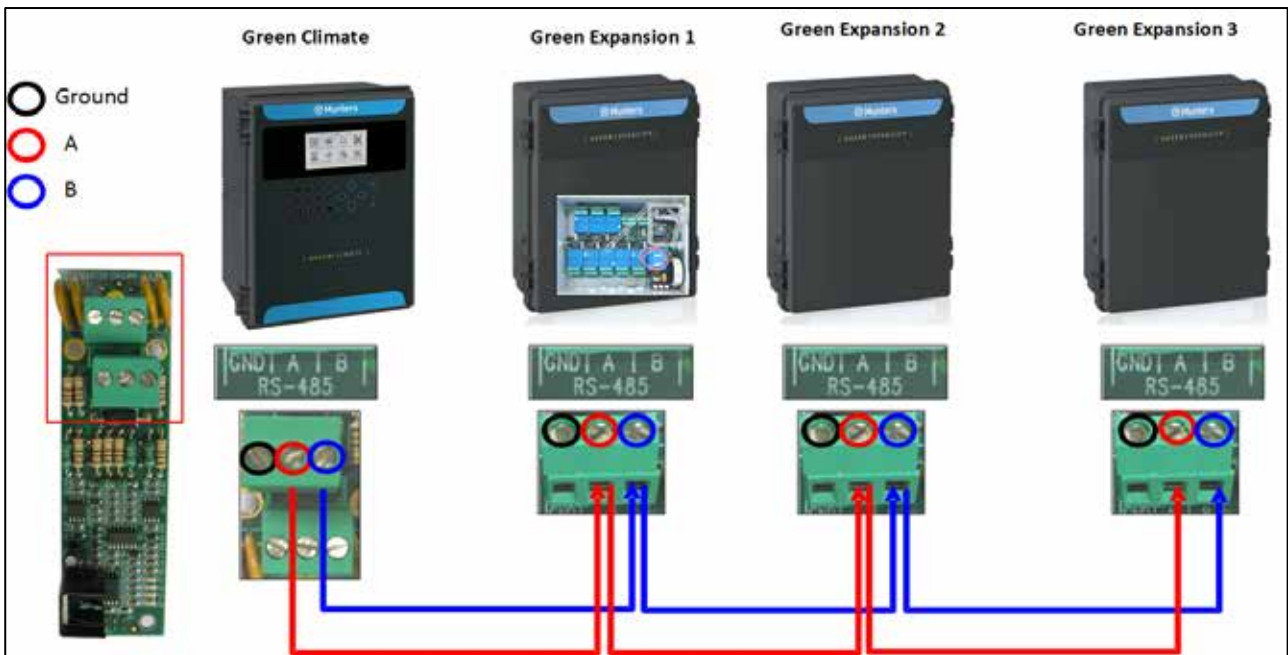

Baud Rate	Distance	One expansion Box
9600 BPS	2000 m	
4800 BPS	2500 m	
2400 BPS	3000 m	
Baud Rate	Distance	Three Expansion Boxes
9600 BPS	1200 m	
4800 BPS	1800 m	
2400 BPS	2400 m	

Baud Rate	Distance	One expansion Box
9600 BPS	2000 m	
4800 BPS	2500 m	
Baud Rate	Distance	Three expansion Boxes
9600 BPS	1200 m	
4800 BPS	1800 m	
2400 BPS	2400 m	

CAUTION WRONG RELAY CONNECTION!

Pay attention that each device's common and command wires are only connected to a single Dry Contact card. DO NOT connect two controllers to a single device. DO NOT connect a common wire to one controller and the command wire to another.

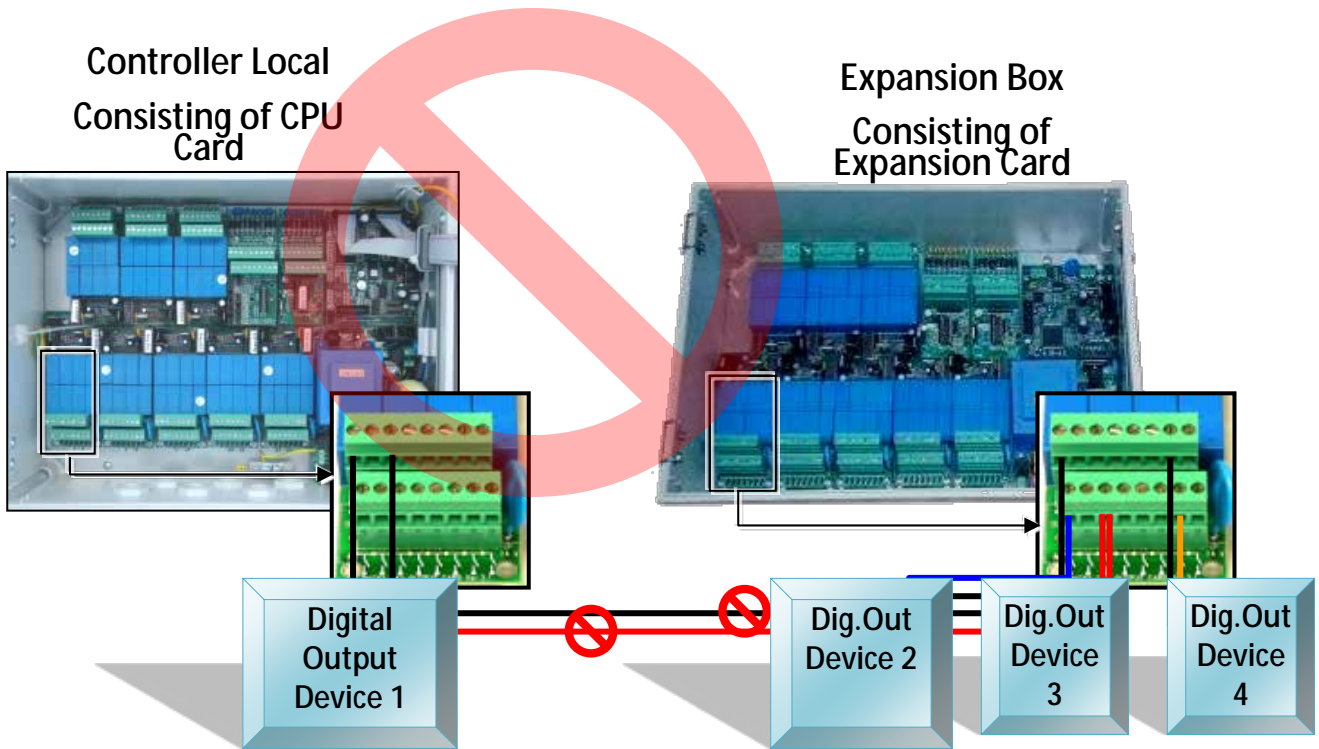

3.7.2 EXPANSION UNIT SETTINGS

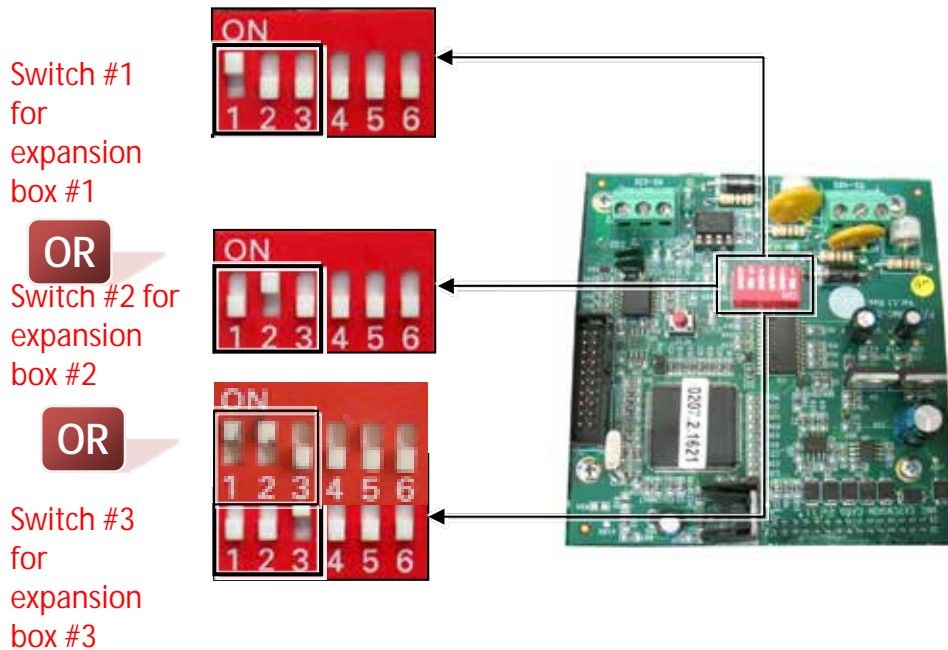

Set Baud Rate through switches '4' and '5'

Available Baud Rates:

State #	Baud Rate	'4' switch position	'5' switch position
1	2400 BPS	OFF	OFF
2	4800 BPS	ON	OFF
3	9600 BPS	OFF	ON
4	19200 BPS	ON	ON



State 1



State
2



State
3



State
4

NOTE Baud rate is dependent on cable length and number of controllers.

3.7.3 COMM-BOX WIRING

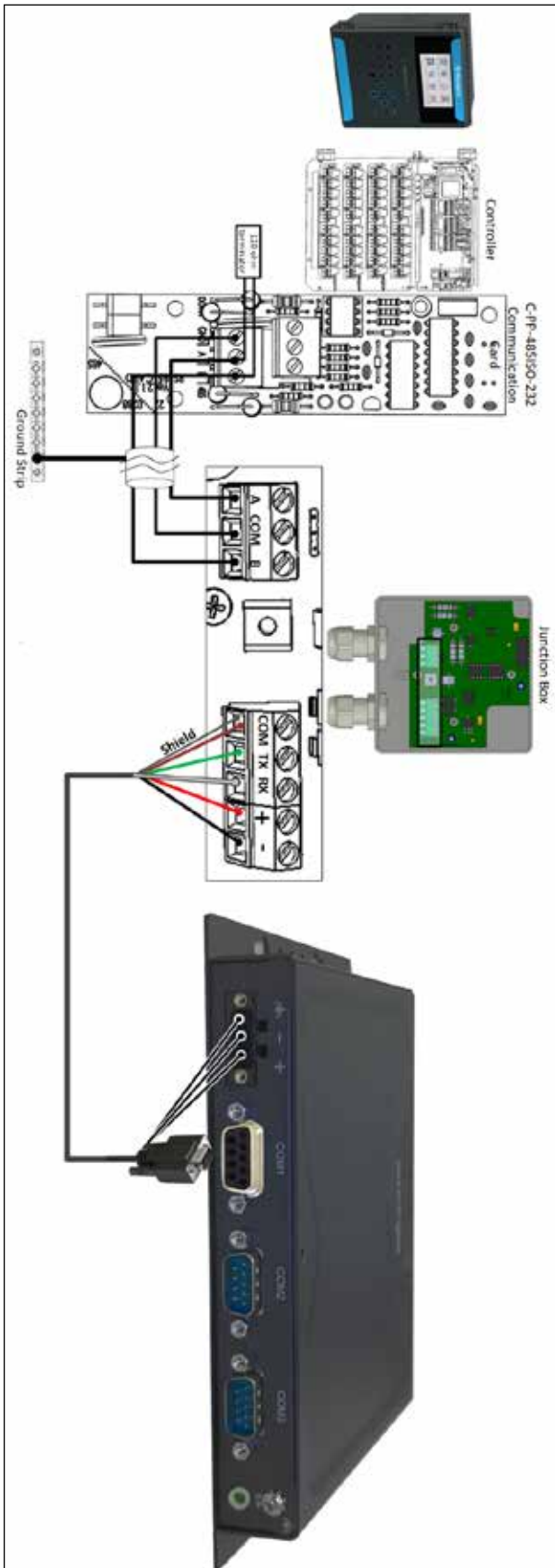

Figure 1: RS-485 Wiring to Comm-Box

NOTE Refer to the Comm-Box Manual on how to log-on to the Comm-Box and manage the controller.

4 System Installation and Configuration

- Firmware Upgrade
- Cold Start
- System Installation (*Menu 8.1*)
- Climate Zone Configuration
- Boiler Configuration

4.1 Firmware Upgrade

The Bootloader application enables installing or updating the system firmware. The application is menu based and simple to use and enables updating the firmware from an SD card or a PC.

NOTE If you plan on updating the firmware from an SD card, verify that the card is in place before starting.

- Accessing the Application
- Running the Application

4.1.1 ACCESSING THE APPLICATION

1. Press and hold the **Left** and **Down** arrow keys.
2. Turn on the unit.

In the screen that appears, enter the password: **38845**.

NOTE If you enter the wrong password, an error message appears and the program goes to the Main Screen. Repeat the process.

3. Press . The screen below appears.

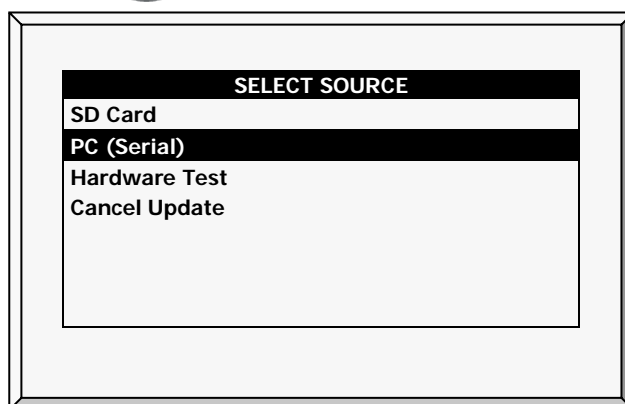

4.1.2 RUNNING THE APPLICATION

NOTE Pressing **Exit** or **ESC** takes you to the previous menu.

1. Select the **SD Card** or **PC**.

NOTE **Hardware Test** is used for quality control only.

- If you choose PC (Serial), a “Flash Programmer” application updates the firmware. Follow the online instructions.

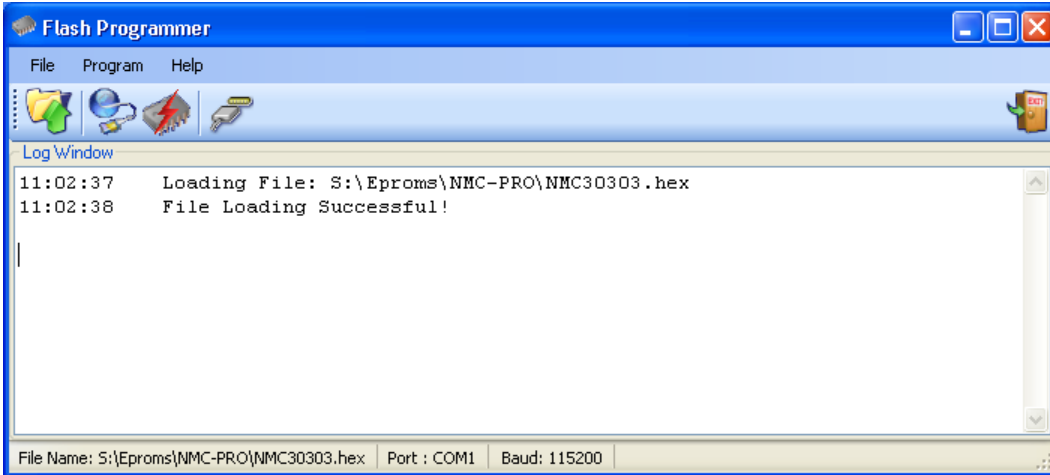

- If you choose SD Card, the following screen appears:

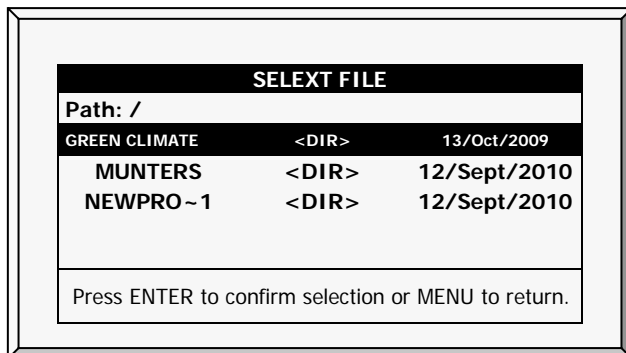

- a. Select the required software.

- b. Press



The following screen appears:

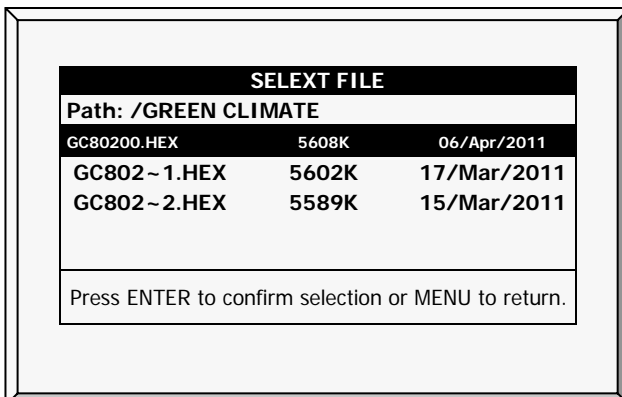

- c. Select the required software version.

d. Press .

2. A confirmation message appears. Select **Yes**.

3. Press .

NOTE Do not turn the unit off during the update! If there is an interruption (for example a power outage), restart the process.

4. At the end of the process, the following screen appears (the version numbers are examples only):



5. Press  and perform a **Cold Start**.

4.2 Cold Start

NOTE To perform a cold start or firmware upgrade, controller must be in Technician mode (refer to User Level Access).

Press the **RED RESET** button on the CPU card, and immediately after, press down on  on the controller until the following screen appears:

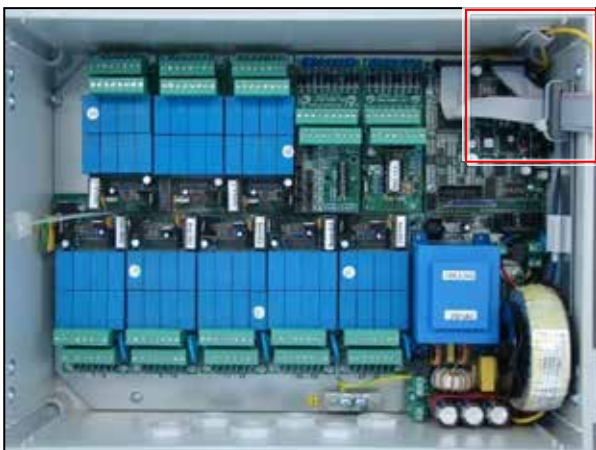

Select **YES** (using arrow keys) and press  to run a **COLD START**.





4.3 System Installation (Menu 8.1)

- Digital Outputs (Menu 8.1.1)
- Digital Inputs (Menu 8.1.2)
- Analog Inputs (Menu 8.1.3)
- View Hardware Checklist (Menus 8.1.4 & 7.10.7)

4.3.1 DIGITAL OUTPUTS (MENU 8.1.1)

8.1.1. Install DO		19/01/09		16:21
Relay	Function	#	Zone	
1	Local	Vent Open	1	Zone1
2	Local	Vent Close	1	Zone1
3	Local	Vent Open	2	Zone1
4	Local	Vent Close	2	Zone1
5	Local	Screen Spread	1	Zone1
6	Local	Screen Collect	1	Zone1
7	Local	Heating On/Off	1	Zone1
8	Local	F&P Fan Stage	1	Zone1
9	Local	CO2 Valve	1	Zone1
10	Local	Crop Prt.Prepa	0	Zone1
11	Local	Misting Pump	1	Zone1



- **Function:** Define the relay function according to the physical wiring location on the card (see Hardware Layout page 13). Place the cursor on the relevant line and press , a selection list will open, choose the appropriate device and press  to confirm.
- **#:** Define the relay's number (per zone). This will be the reference number for all other menus concerning this device.
- **Zone:** Define the zone in which the relay is operating.

NOTE This table refers to both local and extension boxes.

4.3.1.1 Test Relay - Digital Outputs (Menu 6.1)



6.1. Relay test		19/01/09		16:21
Relay	Z	Function	#	State
1	Local	4 Vent Open	1	Off
2	Local	1 Vent Close	1	On
3	Local	2 Vent Open	2	Man
4	Local	3 Vent Close	2	Off
5	Local	2 Screen Spread	1	Off
6	Local	1 Screen Collect	1	Off
7	Local	3 Heating On/Off	1	Off
8	Local	4 F&P Fan Stage	1	On
9	Local	1 CO2 Valve	1	Off
10	Local	1 Crop Prt.Prepa	0	Off
11	Local	1 Misting Pump	1	On

The **Relay Test** screen allows you to check the current output status and verify proper operation. The STATE shows if the device is currently ON or Off. Z (Zone) shows the zone of the relay defined in *Installation > System Installation > Digital Outputs*.

To manually test relay functionality, use  to change the relays STATE to **Man** (Manual) the device will be turned on and the STATE will show **Man** for five minutes before returning to the previous state, or press  again to return to automatic operation.

4.3.2 DIGITAL INPUTS (MENU 8.1.2)

8.1.2. Install DI		19/01/09		16:21
Input		Function	#	Zone
1	Local	Wind Speed	1	WS
2	Local	Extern. Contact	1	Zone1
3	Local	Rain Detector	1	WS
4	Local	Rain Collector	1	WS
5	Local	Vent Opened	1	Zone1
6	Local	Vent Closed	1	Zone1
7	Local	Screen Spread	1	Zone1
8	Local	Screen Collected	1	Zone1
9	Ext	None	0	None
10	Ext	None	0	None
11	Ext	None	0	None

- **Function:** Define the input function according to the physical wiring location on the card (see [Hardware Layout](#) page 13). Place the cursor on the relevant line and press , a selection list will open, choose the appropriate sensor and press  to confirm.
- **#:** Define the input's number (per zone or WS-Weather Station). This will be the reference number for all other menus concerning this sensor.
- **Zone:** Define Zone number or WS for location of sensor.

NOTE This table refers to both local and extension boxes.

4.3.2.1 Test Digital Inputs (Menu 6.3)



6.3. DI test					19/01/09
					16:21
Input	Z	Function	#	Value	
1	LOCAL	2	Wind Speed	1	0
2	LOCAL	2	Extern. Contact	1	1
3	LOCAL	2	Rain Detector	1	0
4	LOCAL	2	Rain Collector	1	0
5	LOCAL	2	Vent Opened	1	1
6	LOCAL	2	Vent Closed	1	0
7	LOCAL	2	Screen Spread	1	0
8	LOCAL	2	Screen Collected	1	0
9	N/A	0	None	0	0
10	N/A	0	None	0	0
11	N/A	0	None	0	0

The **Digital Input Test** screen displays the current state of the input in the VALUE column. When the VALUE column displays a "1" then the contact of the input is currently closed. Whereas a "0" represents that the contact is currently open. Z (Zone) shows the zone of the relay defined in *Installation > System Installation > Digital Inputs*.

NOTE If "5" appears under Zone, the digital input is connected to an external device such as a weather station.

4.3.3 ANALOG INPUTS (MENU 8.1.3)

8.1.3. Install AI					19/01/09	16:21
Input	Function	#	Zone			
1	Local	Temp. In	1	Zone1		
2	Local	Temp. Out	1	WS		
3	Local	None	0	None		
4	Local	None	0	None		
5	Local	None	0	None		
6	Local	None	0	None		
7	Local	Radiation	1	WS		
8	Local	None	0	None		
9	Local	Humidity Out	1	WS		
10	Local	Humidity In	1	Zone1		
11	Local	Wind Dir	1	WS		

- **Function:** Define the input function according to the physical wiring location on the card (see [Hardware Layout](#) page 13). Place the cursor on the relevant line and press , a selection list will open, choose the appropriate sensor and press  to confirm.
- **#:** Define the input's number (per zone or WS-Weather Station). This will be the reference number for all other menus concerning this sensor.
- **Zone:** Define Zone number or WS for location of sensor.

NOTE This table refers to both local and extension boxes.

4.3.3.1 Test Analog Inputs (Menu 6.2)

6.2. AI test		19/01/09		16:21	
Input	Z	Function	#	Value	
1	Local	1	Temp. In	1	496
2	Local	1	Temp. Out	1	575
3	Local	0	None	0	1023
4	Local	0	None	0	192
5	Local	0	None	0	0
6	Local	0	None	0	118
7	Local	1	Radiation	1	174
8	Local	0	None	0	1
9	Local	1	Humidity Out	1	382
10	Local	1	Humidity In	1	303
11	Local	1	Wind Dir	1	526

The **Analog Test** displays the sensors A/D readings, 0 – 1023. **Z** (Zone) shows the zone of the analog input defined in *Installation > System Installation > Analog Inputs*.

NOTE If "5" appears under Zone, the analog input is connected to an external device such as a weather station.

Sensor type	Description
Humidity sensor	RH% = 0; A/D = 0
	RH% = 50; A/D = 308
	RH% = 100; A/D = 620
Temp sensor	T°C = 0; A/D = 768
	T°C = 25; A/D = 489
	T°C = 50; A/D = 250

4.3.4 VIEW HARDWARE CHECKLIST (MENUS 8.1.4 & 7.10.7)

HW CHECKLIST						
DESCRIPTION		LOC.	EXP1	EXP2	EXP3	
Analog Input		2	1	1	1	
Digital Input		1	1	1	1	
Relay Card		6	8	6	5	
Exp. Box Version		--	1.0	1.0	1.0	
Qty. Climate RTU		4	3	3	3	
COM	Relay 57-64	Relay 56-49	A. In No. 2	A. In No. 1	D. In No. 1	CPU
Relay 1-8	Relay 9-16	Relay 17-24	Relay 25-32	Relay 33-40	P.S.	

Abbreviation Legend:

- **COM** – Communication card location
- **Relay** – 24VAC or Dry Contact Output
- **A.In** – Analog Input card
- **D.In** – Digital Input card

- P.S. – Power Supply
- Verify all components that were installed are displayed on the Hardware Checklist screen.

4.4 Climate Zone Configuration

- Zone Configuration (Menu 8.2.11)
- Measuring Box Allocation (Menu 8.2.10)
- Vent (Menu 8.2.1)
- Screen (Menu 8.2.2)
- Heating (Menu 8.2.3)
- Misting (Menu 8.2.4)
- Fan & Pad (Menu 8.2.5)
- Air Circulation (Menu 8.2.6)
- CO2 (Menu 8.2.7)
- Crop Protection (Menu 8.2.8)
- Light (Menu 8.2.9)

4.4.1 ZONE CONFIGURATION (MENU 8.2.11)

8.2.11. ZONE CONF	Zone 1	19/01/09	16:21
1. Zone height meter		5.0	
2. Zone length meter		100.0	
3. Zone width meter		90.0	
4. Air exch. w zone close 1/h		0.2	
5. Cover type		glass	

Press the ZONE key to select the desired zone to configure

- **Zone height:** define the height (from floor level to ceiling) of the zone in meters
- **Zone length:** define the length (along eastern or western side) of the zone in meters
- **Zone width:** define the width (along northern or southern side) of the zone in meters
- **Air exchange when zone is closed:** define the amount of air that was exchanged within one hour for the zone (according to zone cover type)
- **Cover type:** select which type of cover is used for the zone (glass, plastic)

4.4.2 MEASURING BOX ALLOCATION (MENU 8.2.10)

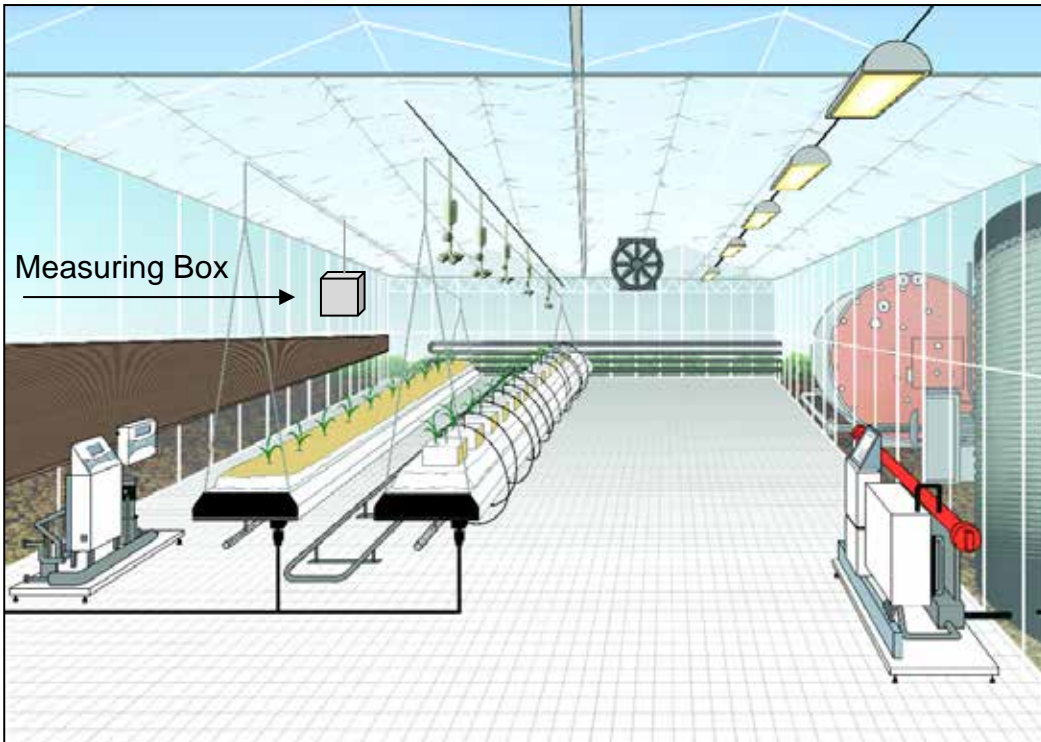

8.2.10. Meas Box Allocation	Zone 1	19/01/09 16:21			
Measuring Box	1				
1. Zone Overvie					
2. Top1 Vent Cn					
3. Top2 Vent Cn					
4. Top3 Vent Cn					
5. Top4 Vent Cn					
6. Lng Side Cnt					
7. End Side Cnt					
8. Screen 1					
9. Screen 2					
10. Air Circ					
11. CO2					
12. Misting					
13. Fan and Pad					
14. Heating					
15. Net Head 1					
16. Net Head 2					
17. Net Head 3					
18. Net Head 4					
19. Net Heat Floor					

For each function define if a measuring box or boxes are being used for program operation. Use



to make your selection. If using several measuring boxes for a single function then define the

Cntrl – Avg: Average of sensors; High: highest value among sensors; Low: lowest value among sensors.

4.4.3 VENT (MENU 8.2.1)

8.2.1. Vent cfg.	Zone 1	19/01/09	16:21
1. Vent #	1	2	3
2. Controlled by	Top1	LSide	ESide
3. Vent direction°	0	90	180
4. Position w F&P %	50	50	50
5. Min vent w F&P %	20	20	20
6. Open time mm:ss	02:00	02:00	02:00
7. Close time mm:ss	02:00	02:00	02:00
8. Run delay mm:ss	00:00	00:00	00:00
9. Extra run time	00:03	00:03	00:03
10. Calib. Curve	↙	↙	↙
11. Wind pos w Frost	0	0	0
12. Lee pos w Frost	0	0	0

#	Parameter	Explanation	Unit/Range	Default
1.	Vent Type	Define the control that the Vent is connected to.	1-6	
2.	Vent Control	Define the Vent Type: Top1 - 4, LSide, ESide, and None.		Top1
3.	Vent Direction	Define the direction of the vent in degrees, relative to the north (this parameter is used to decide if the vent is lee or wind)	0-360°	--
4.	Vent Position when Fan&Pad Event starts	Define the position of the vent when a Fan&Pad event starts.	0-100%	0%
5.	Minimum Vent Position with Fan&Pad	Define the minimum vent position to enable the Fan&Pad.	0-100%	0%
6.	Opening Run Time	Define the amount of time the vent takes from fully CLOSED to fully OPEN	mm:ss	02:00
7.	Closing Run Time	Define the amount of time the vent takes from fully OPEN to fully CLOSED	mm:ss	02:00
8.	Running Delay	Define the delay time, the time it takes from applying the open/close command until the operation starts	mm:ss	00:01
9.	Extra Run Time	The extra time after the vent is fully CLOSED (0%) or fully OPENED (100%) to make sure that the vent is completely opened or closed	mm:ss	00:20
10.	Vent Calibration Curve	A four point table used to define the vent physical positions and measured position voltage.	0 – 100% (position) 0 – 5000 mV	0 0

#	Parameter	Explanation	Unit/Range	Default
11.	Wind vent position during Frost Event	The position of the vent during an Emergency Frost event <i>NOTE: Done By Factory Technician – cannot be configured by the Technician</i>	0-100%	0
12.	Lee vent position during Frost Event	The position of the vent during an Emergency Frost event <i>NOTE: Done By Factory Technician – cannot be configured by the Technician</i>	0-100%	0

4.4.4 SCREEN (MENU 8.2.2)

8.2.2. Screen cfg.	Zone 1	19/01/09	16:21
1. Screen #	1	1	
2. Energy saving %	20	20	
3. Rad transfer %	70	70	
4. Use snow protection	YES	YES	
5. Step size per stage %	10	10	
6. Delay between step mm:ss	00:05	00:05	
7. Temp for active snow°C	3.0	3.0	
8. Spread run time mm:ss	02:00	02:00	
9. Collect run time mm:ss	02:00	02:00	
10. Run delay mm:ss	00:01	00:01	
11. Extra run time mm:ss	00:20	00:20	
	↙	↙	

#	Parameter	Explanation	Unit/Range	Default
1.	Screen number	Screen number referring to Installation Digital Output	1-2	
2.	Energy saving %	Define the energy saving percent as defined by the screen manufacturer. In cases where there are two screens, one above another, the energy saving percent will be the sum of the two screens.	0-100%	20%
3.	Radiation Transferability	The transferability of light as defined by the screen manufacturer	0-100%	70%
4.	Snow Protection	Define if to operate during snow protection.	Yes/No	Yes
5.	Step Size per stage during a snow event	Define the size of each step of the screen during a snow event	0-100%	10%
6.	Delay between steps during a snow event	Define the delay between each step during a snow event	mm:ss	00:00

#	Parameter	Explanation	Unit/Range	Default
7.	Air temperature set point to indicate snow	Define the air temperature that should be measured in order to indicate a snow event. This will protect against faulty indications of the snow detector.	-50°C to +50°C	3°C
8.	Spreading Run Time	Define the time that the screen takes from fully CLOSED to fully OPEN	mm:ss	02:00
9.	Collecting Run Time	Define the time that the screen takes from fully OPEN to fully CLOSED	mm:ss	02:00
10.	Running Delay	Define the delay time, the time it takes from applying the open/close command until the operation starts	mm:ss	00:01
11.	Extra Run Time	The extra time after the screen is fully CLOSED (0%) or fully OPENED (100%) to make sure that the screen is completely opened or closed	mm:ss	00:20

4.4.5 HEATING (MENU 8.2.3)

8.2.3. Heating cfg.		Zone 1	19/01/09	16:21
1.	Network #	1	2	
2.	Capacity On/Off kW	----	----	
3.	P factor	7.0	7.0	
4.	I factor	5	5	
5.	Low Flow Rate m3/h	1	1	
6.	High Flow Rate m3/h	1	1	
7.	HS pump power kW	0	0	
8.	LS pump power kW	0	0	
9.	MV Adjust factor s.	0.5	0.5	
10.	MV Min Pulse s.	1.0	2.0	

	Parameter	Explanation	Unit/Range	Default
1.	Network number	<p>Networks Available</p> <ul style="list-style-type: none"> Four heating networks available per zone: 4-networks x 4-zones) One optional Floating Network available per Zone (defined on a single zone only) One ON/OFF heating system per zone 	<p>Network 1-4 Floating Network ON/OFF</p>	None
ON/OFF heating – Configuration 2-3				
2.	Capacity for On/Off heat	The electrical capacity of the On/Off heating system	0-50000kW	--
For each Water Network heating – Configuration 3-12				
3.	P factor	P factor for the heating network, used to reach the desired temperature through proportional	0-10	7

	Parameter	Explanation	Unit/Range	Default
		error between the measured air temperature and the desired air temperature		
4.	I factor	I factor for the heating network, used to reach the desired temperature	0-10	3
5.	Low Flow Rate m ³ /h	The pump high flow / low flow rate	0-350 m ³ /h	25
6.	High Flow Rate m ³ /h			
7.	HS Pump Electrical Power	The pump high speed / low speed electric power	0-9999 kW	0
8.	LS Pump Electrical Power			
9.	MV Adjust Factor s.	This parameter defines the pulse length required to increase or decrease the heating network's temperature by 1° C. Recommended factor equal 1/200 of the mixing valve runtime.	0.0 to 3600.0 seconds	0.5 seconds
10.	MV Min Pulse s.	The minimum pulse length to open/close the mixing valve. The mixing valve will not open/close with a calculated control pulse below the minimum pulse.	0.0 to 3600.0 seconds	1.0 second

4.4.5.1 Heating Network – P & I Tuning Process

Green Climate attempts to keep the greenhouse temperature close to the set point entered by the user (Heating Program-Parameter # 1.3.4). To do this, the controller receives feedback from the temperature sensors and continuously calculates and adjust the output (Open / Close mixing valve). These calculations are based on the PI algorithm where:

- P is the Proportional factor
- I is the Integral factor

The P and I factor values range from 0-10.

While installing a heating system with an Green Climate controller, calibrate the system to achieve precise control on the Zone temperature.

- The P factor determines the system reaction; a higher P lengthens the opening time / closing time of the mixing valve, which causes faster changes in temperature (both increases and decreases).
- The I factor determines the deviation from the target temperature. It is actually the accumulated error of the measured temperature from the desired temperature.

The combination of the P and I calibration enable superior system.

Calibrate the system:

- when installing
- when climate conditions change

Below is example of a system being calibrated after installation:

- Enter the median P and I. P=5, I=1, and Dead band = 3.0 degree (#1.3.10-11).
- Monitor the results of the system for few hours (overnight).
- According to the results, adjusting the P & I factors:
 - Increase or decrease the P and I depending on the overshooting.

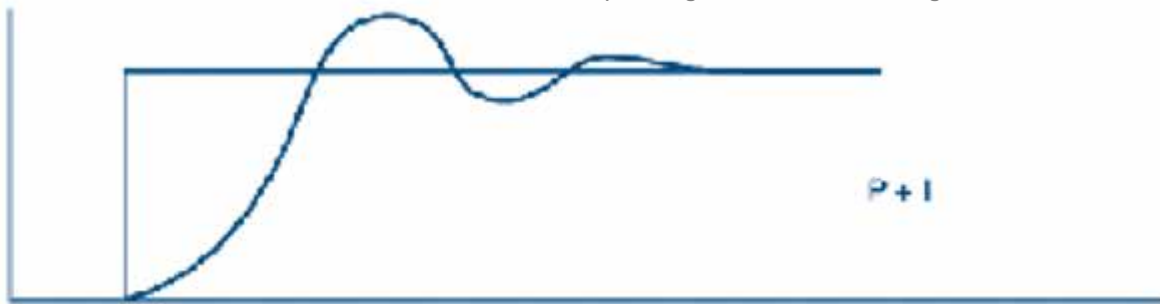

NOTE Wait until you have sufficient results before adjusting the parameters.

NOTE When adjusting the parameters, raise or decrease the level by one unit per day only.

4.4.6 MISTING (MENU 8.2.4)

8.2.4. Misting cfg	Zone 1	19/01/09	16:21
1. Mist Pump			Pump 1
2. Pump Pre run time mm:ss			00:15
3. Pump Post run time mm:ss			03:00
4. Max mist valve together			2
5. Temp P factor %			75
6. Temp I factor %			25
7. Humidity P factor %			75
8. Humidity I factor %			25
9. VPD P factor %			75
10. VPD I factor %			25
11. Misting Pump capacity KW			2.5
12. Remote Pump number			---

#	Parameter	Explanation	Unit/Range	Default
1.	Misting Pump	There may be up to 4 pumps, the technician selects the pump for Zone "X" <i>NOTE: It is possible for more than one zone to use the same pump</i>	Pump 1 – 4 Remote No Pump	Pump 1
2.	Pump Pre-run time	The time that the pump starts before opening the misting valves in the zone	mm:ss	00:15
3.	Pump Post-run time	The time that the pump continues after the last misting valve is closed	mm:ss	03:00
4.	Maximum Misting valves together	The maximum number of misting valves allowed at the same time (per zone)	1 – 8	2
5. 7. 9.	<u>P Factor</u> for Temp, Humidity, and VPD	P & I factors are used for the P.I. correction process. (P) and (I) are the	1 – 100%	75

#	Parameter	Explanation	Unit/Range	Default
6. 8. 10.	I Factor for Temp, Humidity, and VPD	aggressiveness of the adjustment of spray and pause time. <i>The calculation is explained after this table*</i>	1 – 100%	25
11.	Misting pump capacity	Misting pump capacity in kilowatts		2.5
12.	Remote Pump number	In cases where the misting pump (parameter 1) is defined as REMOTE, define in this parameter which pump number it corresponds to	Pump 1 – 4	...

The calculation of the 'Pulse On time' and 'Pause time' is done per each valve per zone, during the period time. The calculation is done according to the set-point that starts the misting process and the measured value inside the greenhouse. The values of the 'Pulse On time' and 'Pause time' are varied between the minimum and the maximum values of the ON/OFF time that were defined per valve.

- The system gets the start trigger set-point – Temp or Humidity or VPD
- Controller measures the current value of – Temp or Humidity or VPD
- In parallel – calculates the new P factor and I factor
- Calculates the desired capacity
- According to the desired capacity, the system finds the calculated 'Pulse time' and 'Pause time' as follow. The minimum and maximum pulse and pause time are per valve, per zone.

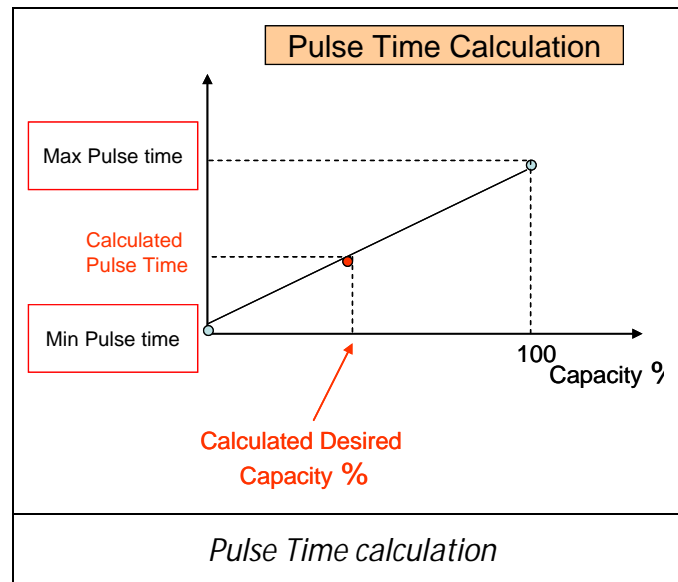

4.4.7 FAN & PAD (MENU 8.2.5)

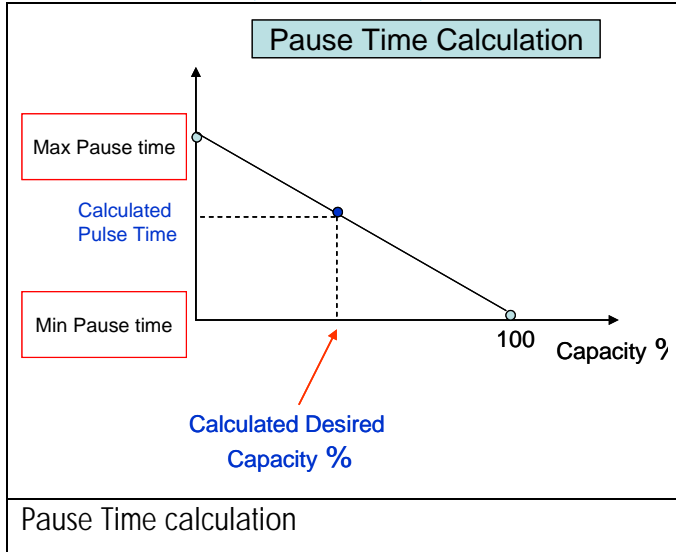

8.2.5. F&P cfg	Zone 1	19/01/09	16:21
1. Fan capacity kW			9.0
2. Pad Pump capacity kW			1.0
3. Min out temp for hum rel.			17.0
4. Air inlet release			Yes
5. Run time open mm:ss			02:00
6. Run time close mm:ss			02:00
7. Run time delay mm:ss			00:00
8. Extra run time mm:ss			00:05
9. Min inlet Pos for F&P %			10
10. Max air inlet w/rain %			11
11. Air inlet w/storm %			8
12. Air inlet when frost %			14
13. Air inlet Curve MV/Pos %			↙

#	Parameter	Explanation	Unit/Range	Default
1.	Fan Capacity	Total power of fan in kilowatts	kW	9.0
2.	Pad Pump Capacity	Total power of pad pump in kilowatts	kW	7.5
3.	Minimum Out Temperature for Humidity Release	Set the minimum outside air temperature to enable humidity release	0 – 100° C	0
4.	Air Inlet release	Option to allow the Fan&Pad inlet to operate	Yes/No	Yes
5.	Air Inlet Run time open	Time it takes for the Fan&Pad inlet to open	mm:ss	00:00
6.	Air Inlet Run time close	Time it takes for the Fan&Pad inlet to close	mm:ss	00:00
7.	Air Inlet Run time delay	Time that the Fan&Pad inlet waits before opening/closing	mm:ss	00:00
8.	Air Inlet Extra run time	The added time that the Fan&Pad inlet runs to ensure that it is completely open/closed	mm:ss	00:00

#	Parameter	Explanation	Unit/Range	Default
9.	Minimum Air Inlet Position for F&P	Define the minimum position of the air inlet to enable beginning the Fan&Pad operation	0 – 100%	10%
10.	Maximum Air Inlet Position during Rain Event	Define the maximum air inlet position when there is a rain event	0 – 100%	0%
11.	Air Inlet Position during Storm Event	Define the maximum air inlet position when there is a storm event	0 – 100%	0%
12.	Air Inlet Position during Frost Event	Define the maximum air inlet position when there is a frost event	0 – 100%	0%
13.	Air Inlet Calibration Curve	A four point table used to define the air inlet physical positions and measured position voltage.	0 – 100% (position) 0 – 5000 mV	0 0

4.4.8 AIR CIRCULATION (MENU 8.2.6)

8.2.6. Air Circ cfg		Zone 1	19/01/09	16:21
1.	Circulator capacity kW		0.3	
2.	Num of circulators in zone		6	

#	Parameter	Explanation	Unit/Range	Default
1.	Circulator Capacity	Total capacity of the air circulator in kilowatts		0.3
2.	Number of circulators per zone	The total number of air circulators allowed to operate per zone		6

4.4.9 CO2 (MENU 8.2.7)

8.2.7. CO2 cfg	Zone 1	19/01/09	16:21
1. Max fan transport capc. kW	1000		

#	Parameter	Explanation	Unit/Range	Default
1.	Transport Fan Capacity	The capacity of the fan transport (for history data purposes)	0-9999 Kw	0

4.4.10 CROP PROTECTION (MENU 8.2.8)

8.2.8. Crop cfg	Zone 1	19/01/09	16:21
1. Evaporator elect capacity kW	12		
2. Number of evaporators per zone	42		

#	Parameter	Explanation	Unit/Range	Default
1.	Evaporator Electrical Capacity	Total power of the evaporators in kilowatts	kW	12
2.	Number of Evaporators per Zone	The total number of evaporators allowed per zone	0 - 80	42

4.4.11 LIGHT (MENU 8.2.9)

8.2.9. Light cfg	Zone 1	19/01/09 16:21		
1. Max number of strings together				1
2. Light string #	1	2	3	
3. # lamps in string	20	20	20	
4. Lamp capacity kW	0.1	0.1	0.1	
5. Lamp efficiency %	50	50	50	
6. Area per string m ²	100	100	100	
7. Cover reflection %	50	50	50	

#	Parameter	Explanation	Unit/Range	Default
1.	Max number of strings together	The maximum number of strings that can be operated together in one zone	1-4	1
2.	String number	Index number for the String	Number – according to index	
3.	Number of lamps per string	Define the total number of lamps per specific string	1-9999	20
4.	Lamp capacity	Define the total lamp power in kilowatts	0-10 kW	0.1
5.	Lamp efficiency	Define the total lamp efficiency in percentage	0-100%	50
6.	Area per String	The specific area per one string. This information should be considered for the heating system.	0-9999 m ²	100
7.	Cover Reflection	The reflection of the greenhouse cover – defined per string	0-100%	50

4.5 Boiler Configuration

- Boiler configuration refers to all zones, per controller.
- Boiler configuration per zone defines when the boiler turns on.

8.3. Boiler Cap		Zone 4	19/01/09 16:21
1.	Boiler capacity kW	3000	
2.	Boiler capacity per zone kW	750	

#	Parameter	Explanation	Unit/Range	Default
1.	Boiler Capacity	Boiler electrical capacity for the entire greenhouse	0 – 10,000 kW	3000
2.	Boiler Capacity per Zone kW	Boiler electrical capacity for each zone	0 – 10,000 kW	750

Boiler capacity per zone defines when the boiler supplying hot water to the greenhouse turns on. The boiler can turn on:

- When the calculated energy requirement for any zone is more than 50% of the Boiler Capacity per Zone. In the screen above, the boiler turns on when Zone 4's calculate requirement is 375 kw or higher.
 - When the cumulative energy requirement for all zones is more than 50% of the boiler capacity. In the screen above, the boiler turns on when the zones' cumulative energy requirement is 1500 kw or higher.
 - In addition, Humidity Release can cause the boiler to turn on. Refer to the User Manual for details.
1. Go to System Installation > System Installation > Digital Inputs.
 2. Define an input as Boiler On.
 3. Define a zone.
 4. Go to System Installation > Boiler Configuration.
 5. Define the boiler capacity.
 6. Select a zone.
 7. Define the zone's boiler capacity per zone.
 8. Repeat steps 4 to 7 for each zone.

*NOTE The Boiler Capacity must be **equal to or greater than** the cumulative Boiler Capacities per Zone.*

5 Technical Specifications

Table 1: General Specifications

Name	Description	Value
Housing	Plastic housing with a screw on lid	IP 65
	Dimensions (LxWxH)	30x40x18 cm (11.81x15.75x7.08 inch)
	Weight	6.0 kg 13.2 lbs
Ambient Conditions	Operating temperature range	0 to +50° Celsius (32 to 122° Fahrenheit)
	Storage temperature range	-10 to +70° Celsius (14 to 158° Fahrenheit)
Approvals	The 115/230VAC has Safety CE approval	EN61010-1
	EMC approvals CE and FCC	<ul style="list-style-type: none"> • EN55011 Group1 Class A • EN61000-3-3; EN61000-6-2; CISPR 11 GROUP 1 CLASS A • FCC Part 15 Subpart B

Table 2: Electrical Specifications

Specifications				
Main voltage	Main frequency	Max voltage	Min voltage	Main fuse
Single phase 230 VAC, 0.5 Amp	50/60 H	250 VAC	200 VAC	0.5 Amp
Single phase 110 VAC, 0.5 Amp	50/60 H	130 VAC	90 VAC	0.5 Amp

CAUTION Green Climate units support 115 VAC, 230 VAC, or both. Each unit has a silver label stating the unit's voltage. Verify that the power supply matches the unit's requirements.

6 Power Supply Specifications

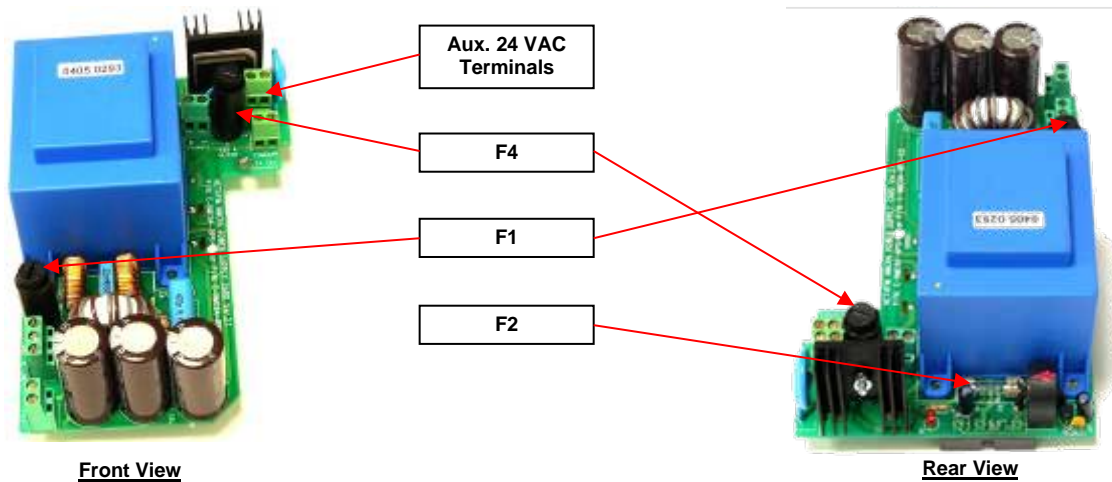

Location	Designation	Type	Style	Rating	Reaction Time	Dimensions
Power Supply, Main Transformer T1	F1	Tubular Glass	M205	1.0 Amp	Slow Blow (T)	20mm x 5mm
Power Supply, CPU & I/O Circuit	F2	Tubular Glass	M205	4.0 Amp	Slow Blow (T)	20mm x 5mm
Power Supply, 24VAC Output Circuit*	F3	Thermal		9.0 Amp	Thermal	
Power Supply, Output Fertigation Trans.	F4	Tubular Glass	M205	1.25 Amp	Slow Blow (T)	20mm x 5mm

* Back side of power supply card

7 Warranty

Warranty and technical assistance

Munters products are designed and built to provide reliable and satisfactory performance but cannot be guaranteed free of faults; although they are reliable products they can develop unforeseeable defects and the user must take this into account and arrange adequate emergency or alarm systems if failure to operate could cause damage to the articles for which the Munters plant was required: if this is not done, the user is fully responsible for the damage which they could suffer.

Munters extends this limited warranty to the first purchaser and guarantees its products to be free from defects originating in manufacture or materials for one year from the date of delivery, provided that suitable transport, storage, installation and maintenance terms are complied with. The warranty does not apply if the products have been repaired without express authorisation from Munters, or repaired in such a way that, in Munters' judgement, their performance and reliability have been impaired, or incorrectly installed, or subjected to improper use. The user accepts total responsibility for incorrect use of the products.

The warranty on products from outside suppliers fitted to Green Climate, (for example Green Climate's antennas, power supplies, cables, etc.) is limited to the conditions stated by the supplier: all claims must be made in writing within eight days of the discovery of the defect and within 12 months of the delivery of the defective product. Munters has thirty days from the date of receipt in which to take action, and has the right to examine the product at the customer's premises or at its own plant (carriage cost to be borne by the customer).

Munters at its sole discretion has the option of replacing or repairing, free of charge, products which it considers defective, and will arrange for their despatch back to the customer carriage paid. In the case of faulty parts of small commercial value which are widely available (such as bolts, etc.) for urgent despatch, where the cost of carriage would exceed the value of the parts, Munters may authorise the customer exclusively to purchase the replacement parts locally; Munters will reimburse the value of the product at its cost price.

Munters will not be liable for costs incurred in demounting the defective part, or the time required to travel to site and the associated travel costs. No agent, employee or dealer is authorised to give any further guarantees or to accept any other liability on Munters' behalf in connection with other Munters products, except in writing with the signature of one of the Company's Managers.

WARNING: In the interests of improving the quality of its products and services, Munters reserves the right at any time and without prior notice to alter the specifications in this manual.

The liability of the manufacturer Munters ceases in the event of:

- dismantling the safety devices;
- use of unauthorised materials;
- inadequate maintenance;
- use of non-original spare parts and accessories.

Barring specific contractual terms, the following are directly at the user's expense:

- preparing installation sites;
- providing an electricity supply (including the protective equipotential bonding (PE) conductor, in accordance with CEI EN 60204-1, paragraph 8.2), for correctly connecting the equipment to the mains electricity supply;
- providing ancillary services appropriate to the requirements of the plant on the basis of the information supplied with regard to installation;
- tools and consumables required for fitting and installation;
- lubricants necessary for commissioning and maintenance.

It is mandatory to purchase and use only original spare parts or those recommended by the manufacturer.

Dismantling and assembly must be performed by qualified technicians and according to the manufacturer's instructions.

The use of non-original spare parts or incorrect assembly exonerates the manufacturer from all liability.

Requests for technical assistance and spare parts can be made directly to the nearest Munters office. A full list of contact details can be found on the back page of this manual.

Munters Israel

18 HaSivim Street

Petach-Tikva 49517, Israel

Telephone: +972-3-920-6200

Fax: +972-3-924-9834

support@munters.co.il



www.munters.com

[Australia](#) Munters Pty Limited, Phone +61 2 8843 1594, [Brazil](#) Munters Brasil Industria e Comercio Ltda, Phone +55 41 3317 5050, [Canada](#) Munters Corporation Lansing, Phone +1 517 676 7070, [China](#) Munters Air Treatment Equipment (Beijing) Co. Ltd, Phone +86 10 80 481 121, [Denmark](#) Munters A/S, Phone +45 9862 3311, [India](#) Munters India, Phone +91 20 3052 2520, [Indonesia](#) Munters, Phone +62 818 739 235, [Israel](#) Munters Israel Phone +972-3-920-6200, [Italy](#) Munters Italy S.p.A., Chiusavecchia, Phone +39 0183 52 11, [Japan](#) Munters K.K., Phone +81 3 5970 0021, [Korea](#) Munters Korea Co. Ltd., Phone +82 2 761 8701, [Mexico](#) Munters Mexico, Phone +52 818 262 54 00, [Singapore](#) Munters Pte Ltd., Phone +65 744 6828, [South Africa and Sub-Sahara Countries](#) Munters (Pty) Ltd., Phone +27 11 997 2000, [Spain](#) Munters Spain S.A., Phone +34 91 640 09 02, [Sweden](#) Munters AB, Phone +46 8 626 63 00, [Thailand](#) Munters Co. Ltd., Phone +66 2 642 2670, [Turkey](#) Munters Form Endüstri Sistemleri A.Ş, Phone +90 322 231 1338, [USA](#) Munters Corporation Lansing, Phone +1 517 676 7070, [Vietnam](#) Munters Vietnam, Phone +84 8 3825 6838, [Export & Other countries](#) Munters Italy S.p.A., Chiusavecchia Phone +39 0183 52 11